

HOW TO find a carbon:

THIS CATALOGUE IS DIVIDED INTO TWO MAIN SECTIONS DISPLAYING TWO TYPES OF CARBON BRUSHES: THOSE WITH HOLDERS AND THOSE WITHOUT. PLEASE REFER TO THE FLOWCHART BELOW WHICH EXPLAINS HOW TO USE THIS CATALOGUE TO FIND SPECIFIC CARBON BRUSHES QUICKLY AND EASILY.

IS CARBON IN A HOLDER?

YES

1) SIZE MATCH (part number order).
Go to pages **6 to 19** and compare the carbon to the drawings.
Drawings are all ACTUAL size - so carbons can be placed on the drawings for an immediate comparison.
This section is ordered by PART NUMBER.

2) PHOTOGRAPHIC MATCH (PART NUMBER ORDER).
Go to page **2** and compare the carbon to the photographs - check possible matches by turning to the page indicated.
Drawings are all ACTUAL size - so carbons can be placed on the drawings for an immediate comparison.
This section is ordered by PART NUMBER.

3) PHOTOGRAPHIC MATCH (OEM ORDER).
Go to pages **3 to 4** and compare the carbon to the photographs of OEM (e.g Indesit) carbons - check possible matches by turning to the page indicated.
Drawings are all ACTUAL size - so carbons can be placed on the drawings for an immediate comparison.
This section is ordered by OEM.

4) PHOTOGRAPHIC MATCH (MOTOR MANUFACTURER ORDER).
Go to page **5** and compare the carbon to the photographs of Motor Manufacturer (e.g Caset) carbons - check possible matches by turning to the page indicated.
Drawings are all ACTUAL size - so carbons can be placed on the drawings for an immediate comparison.
This section is ordered by MANUFACTURER.

NO

Go to pages **20 to 29** and compare the carbon to the drawings.
Drawings are all ACTUAL size - so carbons can be placed on the drawings for an immediate comparison.

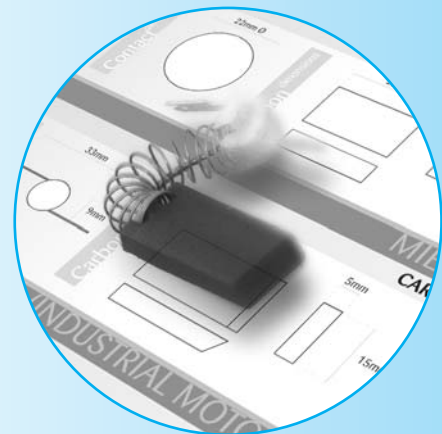

This section is ordered by carbon WIDTH.

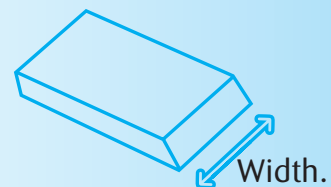

Important note.
Whilst every endeavour has been made to include all OEM & Motor manufacturer information in the respective content pages - method 1 "SIZE MATCH" should always be tried if there appears to be no match.

QUALITY INDEX

CARBON BRUSH REFERENCE MANUAL

ordered by:
"Part Number"

Plain Carbons
WITHOUT HOLDERS

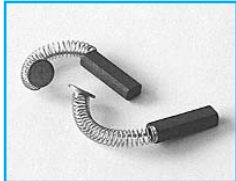

CAR01 - to - CAR94

page no's. 20 - to - 29

Carbons WITH HOLDERS

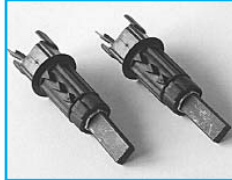

CAR44

page no. 6

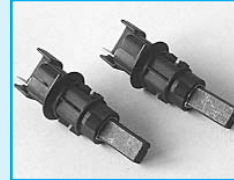

CAR46

page no. 6

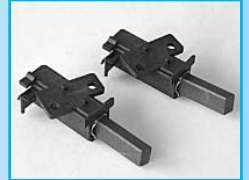

CAR50

page no. 7

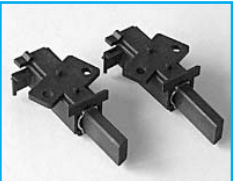

CAR51

page no. 7

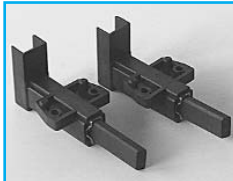

CAR52

page no. 8



CAR53

page no. 8

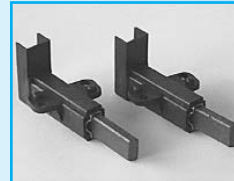

CAR55

page no. 9

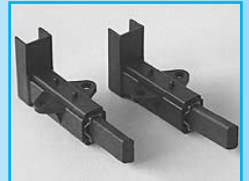

CAR57

page no. 9

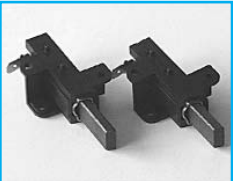

CAR61

page no. 10

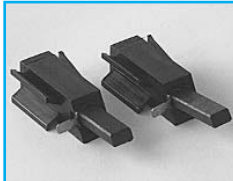

CAR64 (HT)

page no. 10

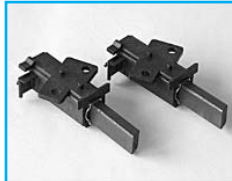

CAR65

page no. 11

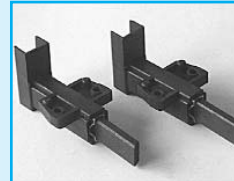

CAR66

page no. 11

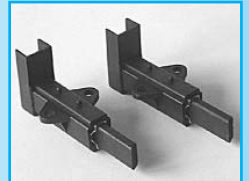

CAR67

page no. 12



CAR69

page no. 12



CAR72

page no. 13



CAR73

page no. 13



CAR75

page no. 14

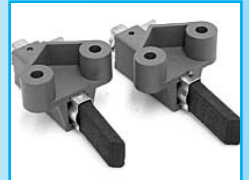

CAR76

page no. 14



CAR77

page no. 15



CAR78

page no. 15



CAR79

page no. 16

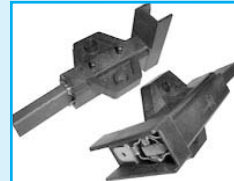

CAR88

page no. 16



CAR89

page no. 17



CAR90

page no. 17

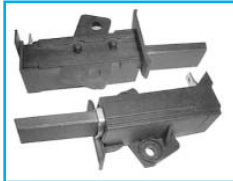

CAR91

page no. 18



CAR95

page no. 18



CAR96 • HPT36

page no. 19 (HT)



CAR97

page no. 19



ordered by:
"OEM"

continued on next page

CARBON BRUSHES WITH HOLDERS PHOTOGRAPHIC INDEX - ordered by OEM

ARISTON

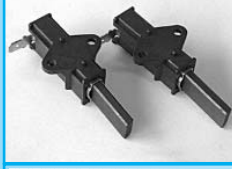

CAR53
page no. 8

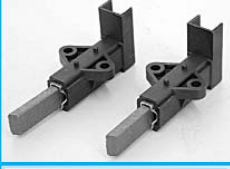

CAR73
page no. 13



CAR77
page no. 15

BOSCH

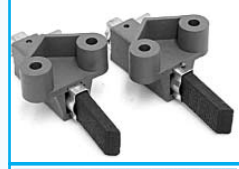

CAR76
page no. 14

BRANDT



CAR79
page no. 16

CANDY



CAR69
page no. 12

CREDA

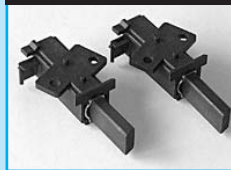

CAR51
page no. 7

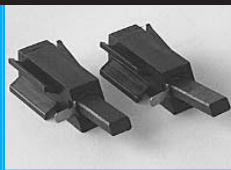

CAR64 (HT)
page no. 10



CAR91
page no. 18



CAR96 • HPT36 (HT)
page no. 19

ELECTRA

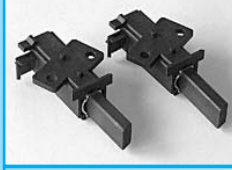

CAR51
page no. 7

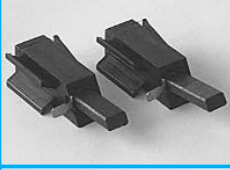

CAR64 (HT)
page no. 10

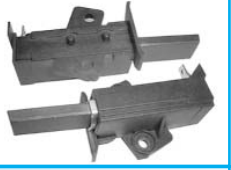

CAR91
page no. 18



CAR96 • HPT36 (HT)
page no. 19

GORENJE



CAR76
page no. 14

HOOVER

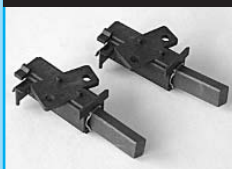

CAR50
page no. 7



CAR75
page no. 14

HOTPOINT

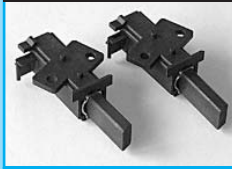

CAR51
page no. 7

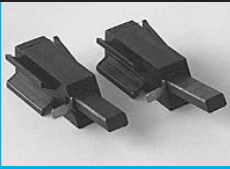

CAR64 (HT)
page no. 10

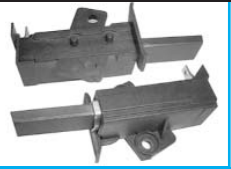

CAR91
page no. 18



CAR96 • HPT36 (HT)
page no. 19

INDESIT (continued on next page)

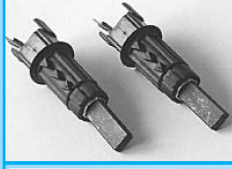

CAR44
page no. 6

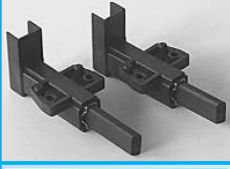

CAR52
page no. 8

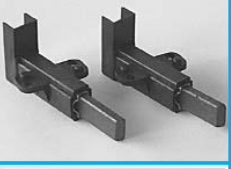

CAR55
page no. 9

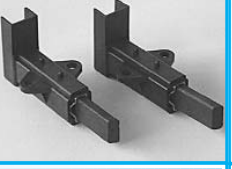

CAR57
page no. 9

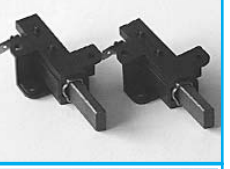

CAR61
page no. 10

QUALTEX

CARBON BRUSH REFERENCE MANUAL

PHOTOGRAPHIC INDEX

ordered by:
"OEM" continued
 from previous page

INDESIT (continued from previous page)

				
CAR66 page no. 11	CAR67 page no. 12	CAR69 page no. 12	CAR72 page no. 13	CAR73 page no. 13

INDESIT (continued)

CAR79 page no. 16

NEW WORLD

CAR73 page no. 13

OCEAN

CAR78 page no. 15

PHILCO

CAR88 page no. 16

PHILIPS

CAR46 page no. 6



QUALTEX

	
CAR95 page no. 18	CAR97 page no. 19

SANGIORGIO

CAR78 page no. 15

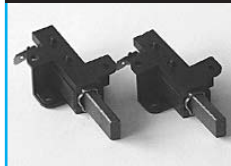

SELNI

	
CAR61 page no. 10	CAR79 page no. 16

SERVIS

CAR55 page no. 9

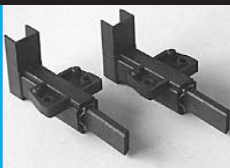
WHIRLPOOL

	
CAR66 page no. 11	CAR69 page no. 12

ZANUSSI

		
CAR53 page no. 8	CAR65 page no. 11	CAR89 page no. 17



AEG	R type	L type
CAR50 page no. 7	CAR51 page no. 7	CAR90 page no. 17

CESET				
CAR52 page no. 8	CAR55 page no. 9	CAR65 page no. 11	CAR66 page no. 11	CAR69 page no. 12

FHP	FISE	INDESCO		
CAR91 page no. 18	CAR97 page no. 19	CAR57 page no. 9	CAR67 page no. 12	CAR88 page no. 16

IBMEI		
CAR76 page no. 14	CAR77 page no. 15	CAR78 page no. 15

SELNI	
CAR61 page no. 10	CAR79 page no. 16

SIX
CAR95 page no. 18

SOLE	
CAR53 page no. 8	CAR89 page no. 17

ZEM
CAR53 page no. 8



INDESIT

1

CAR44

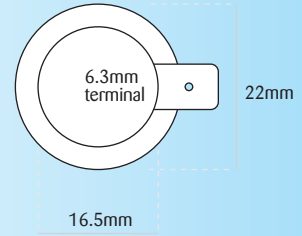
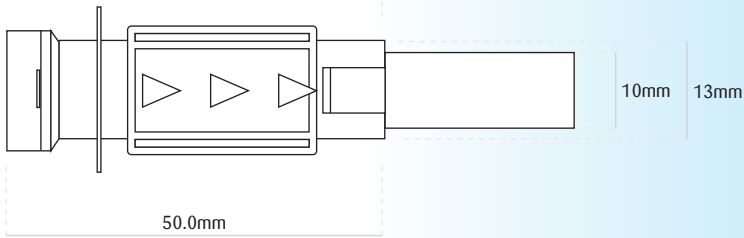
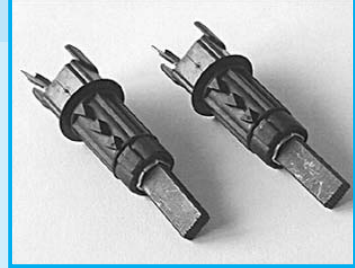
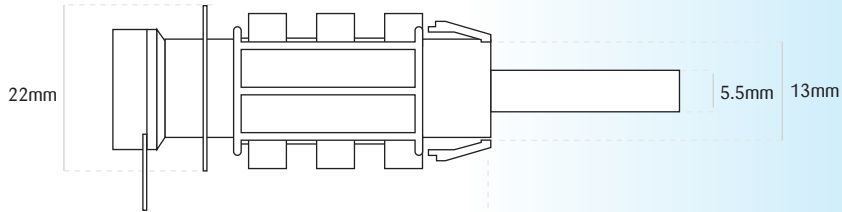

PHILIPS

2

CAR46

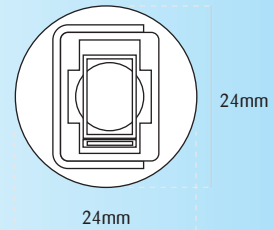
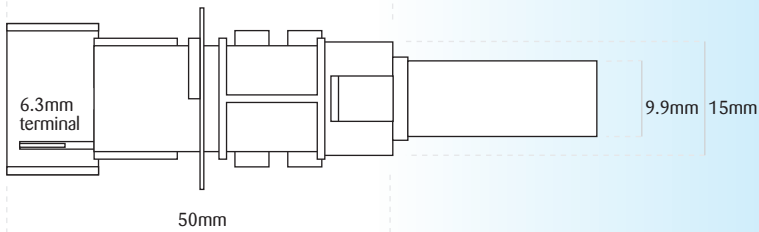
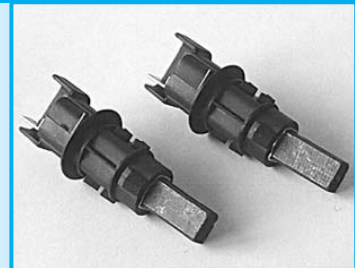
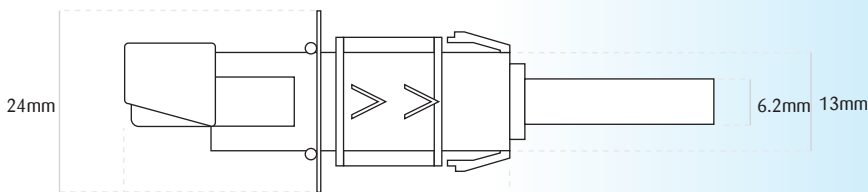

HOOVER (AEG motors)

CAR50

1

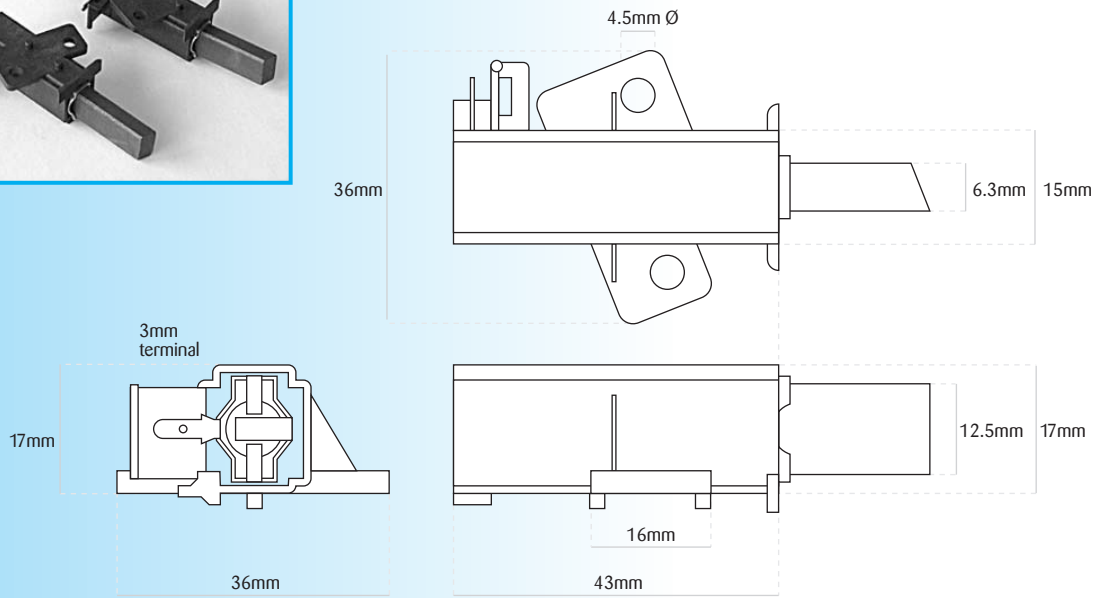
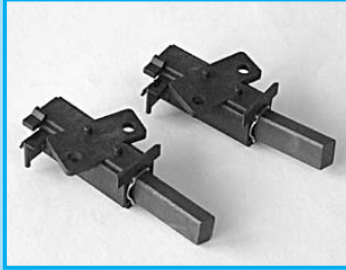

CREDA / ELECTRA / HOTPOINT

CAR51

2

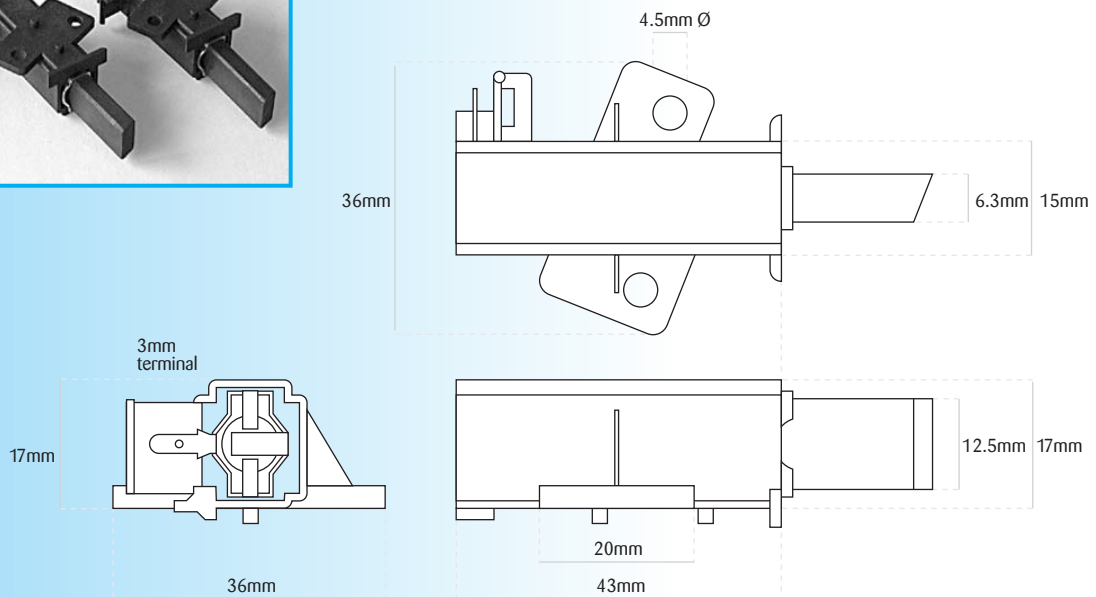
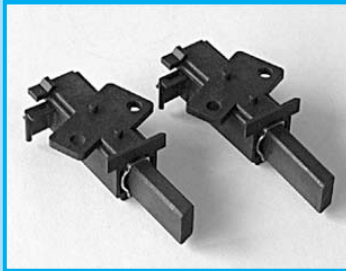



INDESIT (CESET motors)

1

CAR52

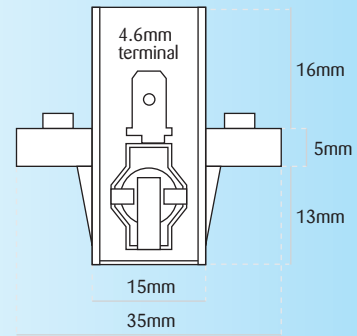
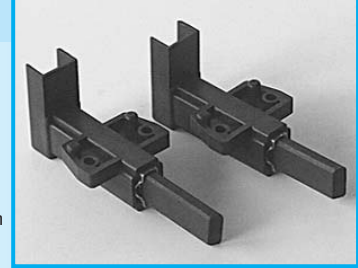
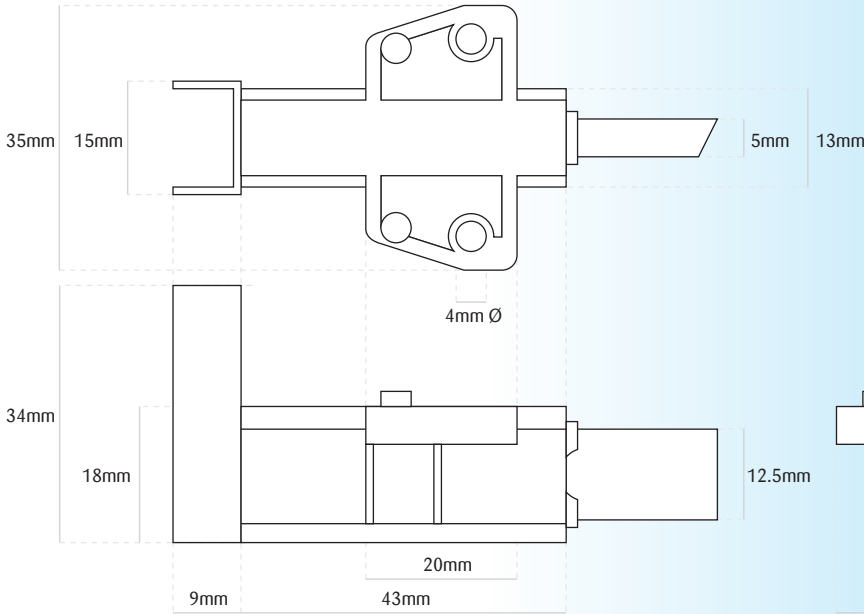

ARISTON / ZANUSSI (SOLE & ZEM motors)

2

CAR53

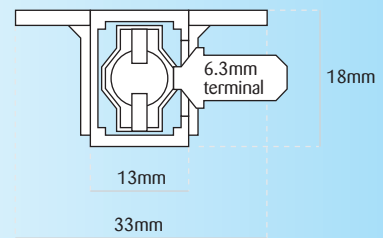
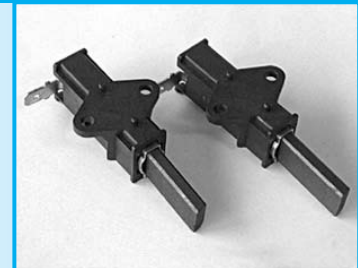
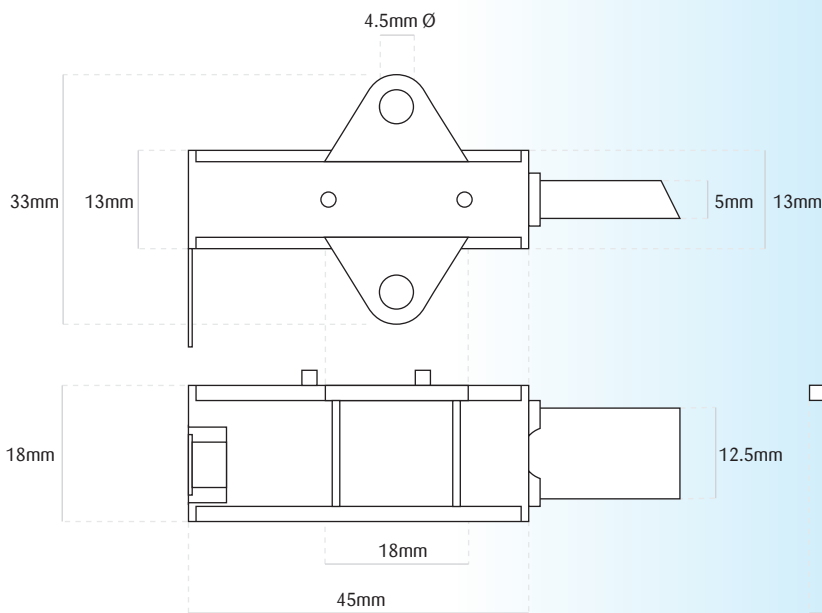

INDESIT / SERVIS (CESET motors)

CAR55 1

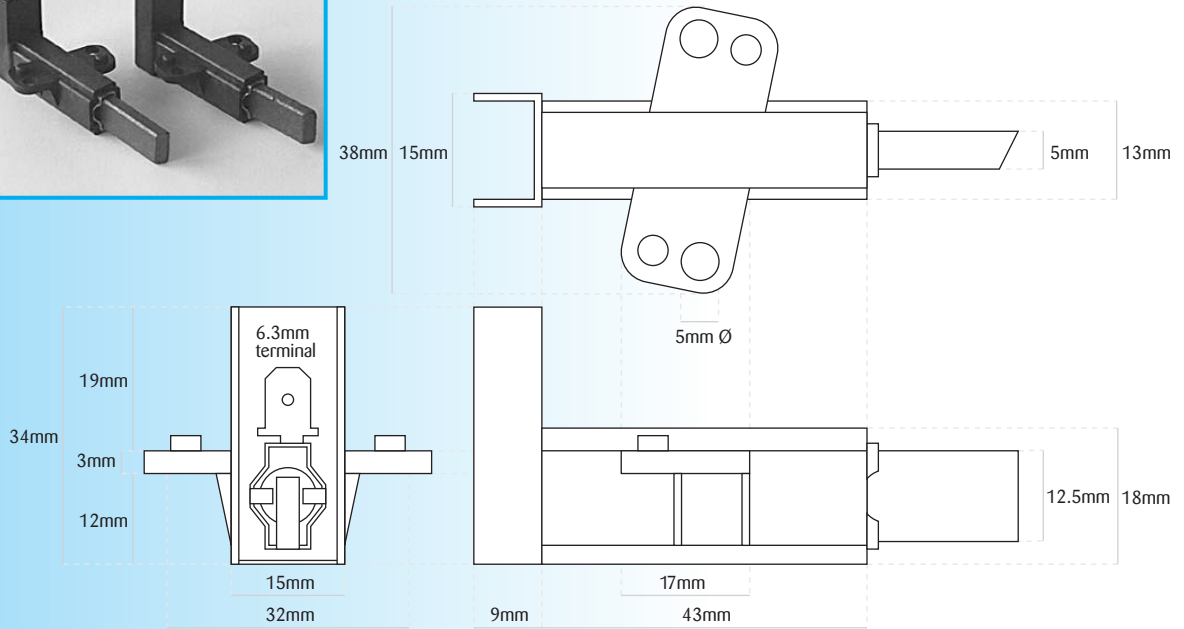
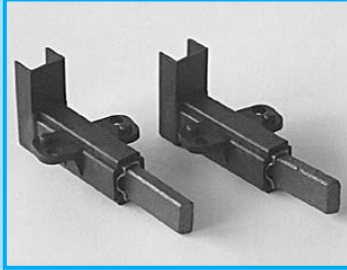

INDESIT (INDESCO motors)

CAR57 2

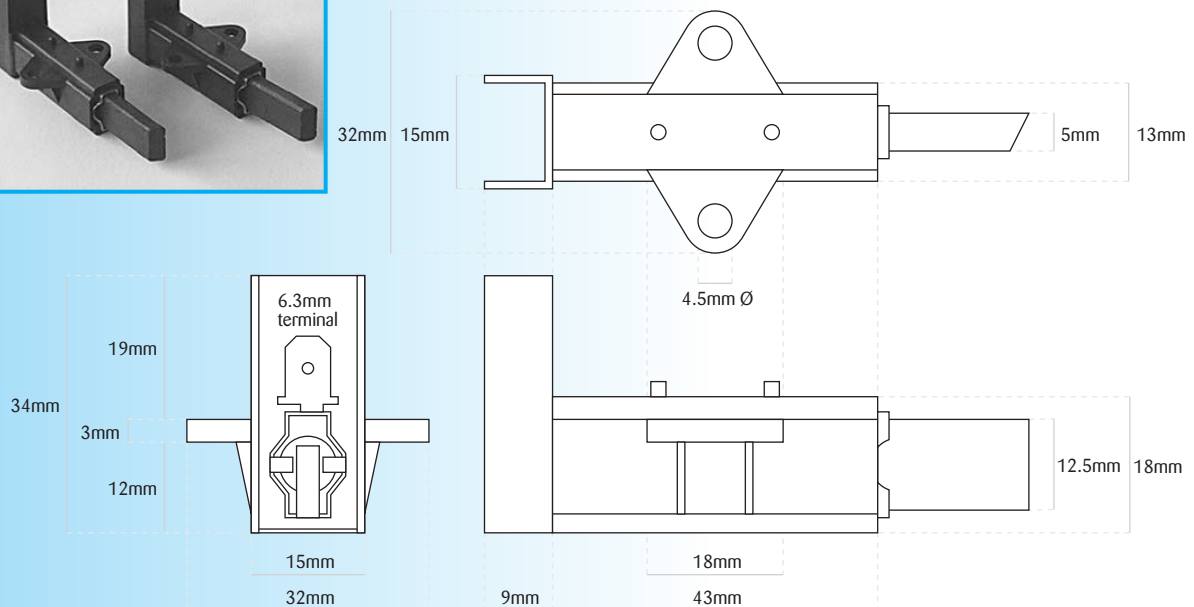
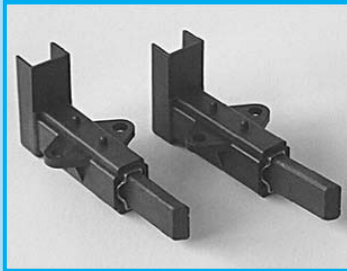

1 INDESIT (SELNI motors)

CAR61

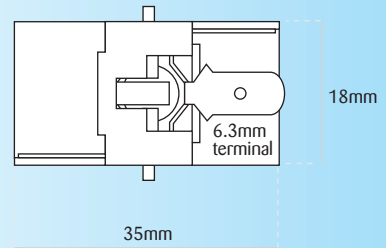
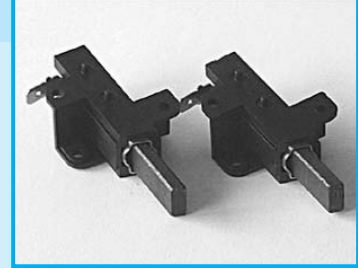
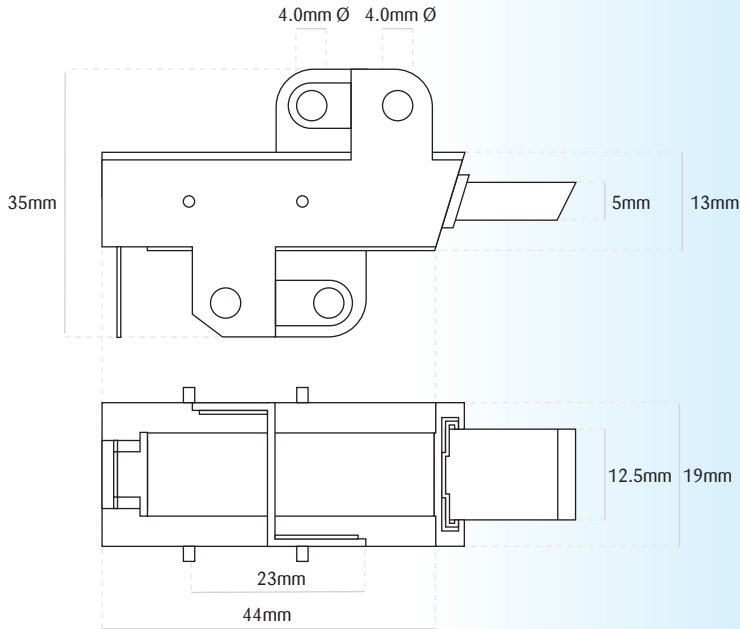

2 CREDIA / ELECTRA / HOTPOINT

CAR64 • CAR64HT (High Temperature) • HPT1600474

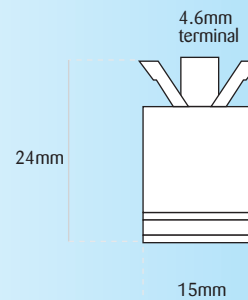
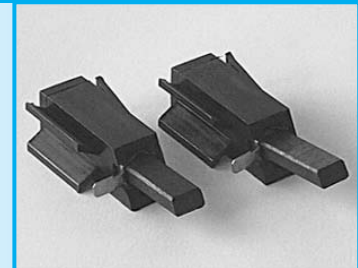
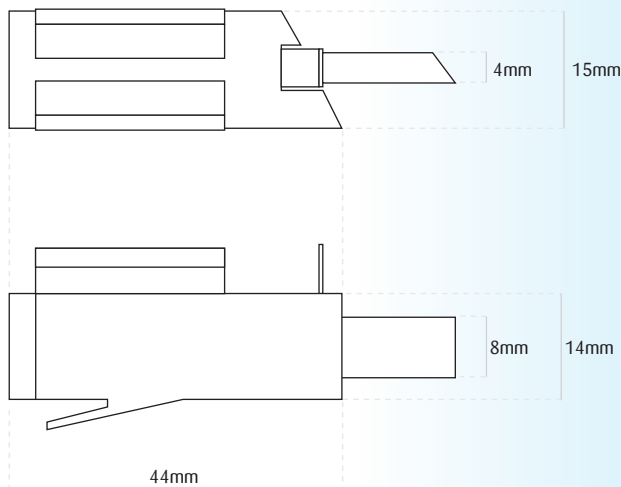

ZANUSSI (CESET motors)

CAR65

1

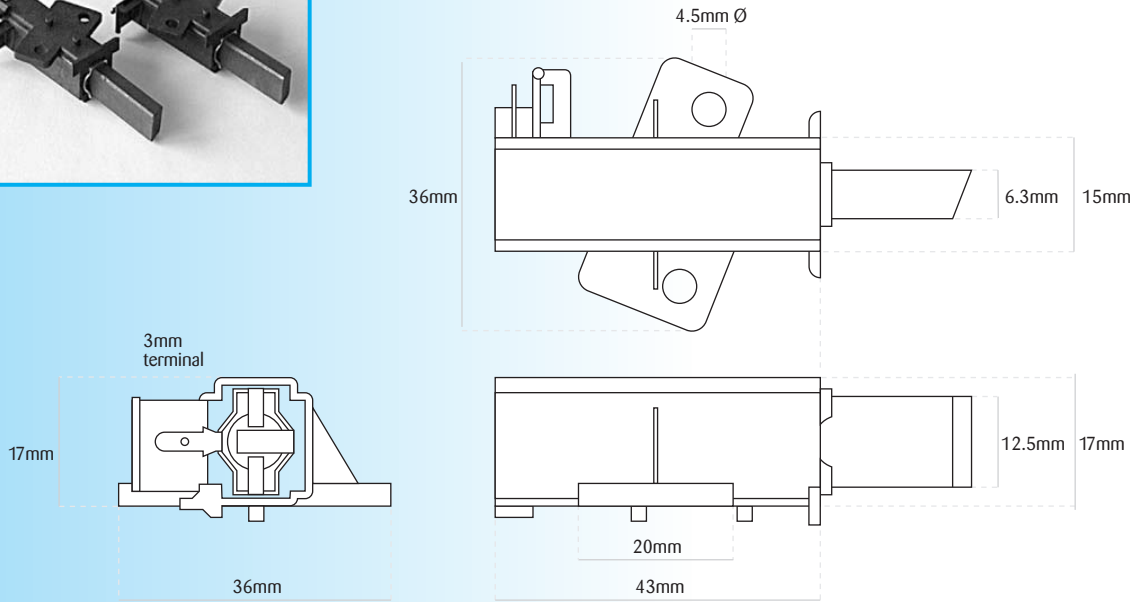
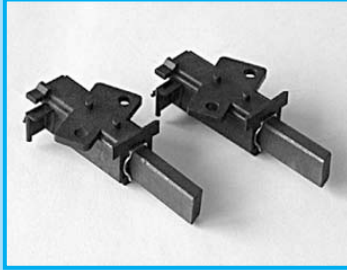

INDESIT / WHIRLPOOL (CESET motors)

CAR66

2

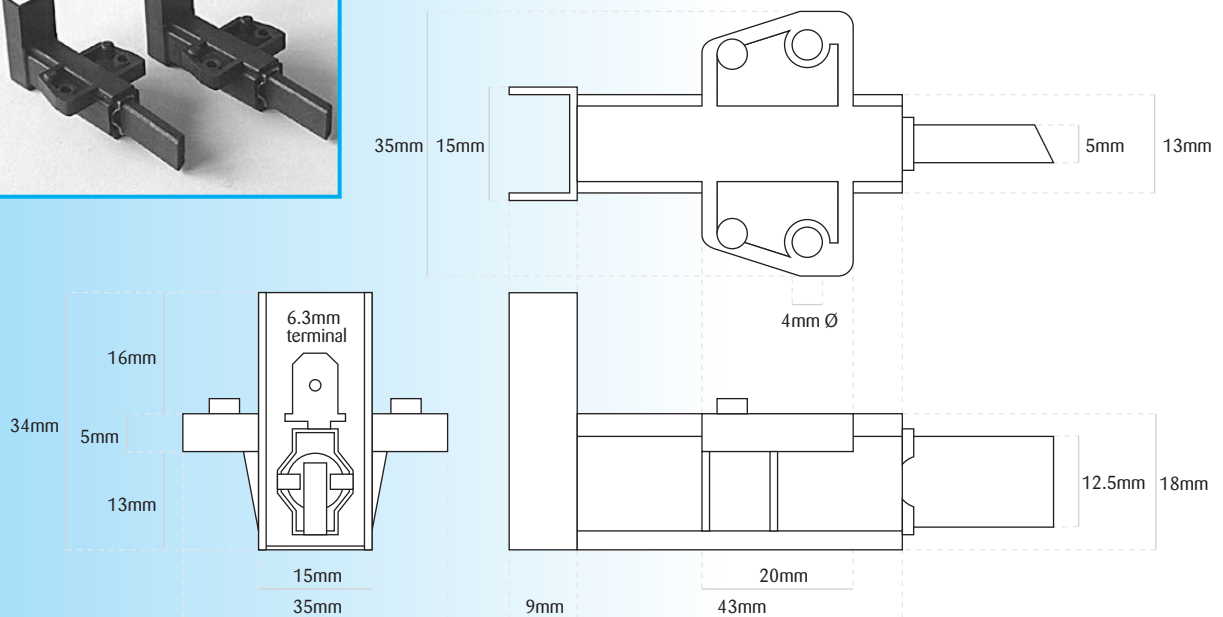
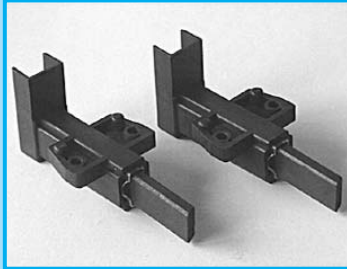



INDESIT (INDESCO motors)

1

CAR67

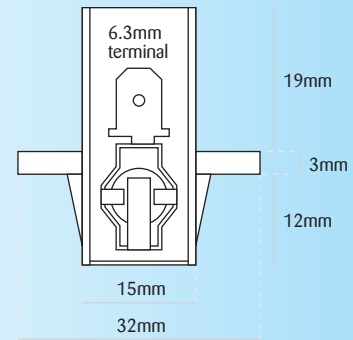
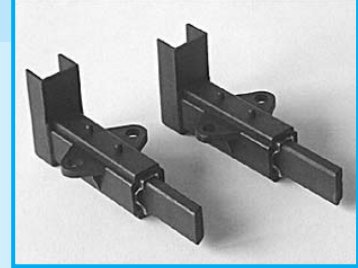
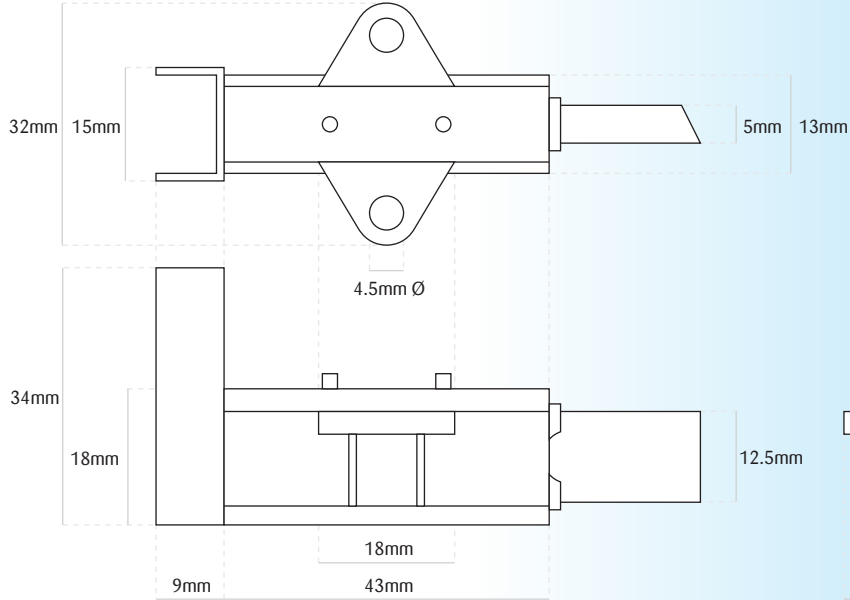

CANDY / INDESIT / WHIRLPOOL

2

CAR69

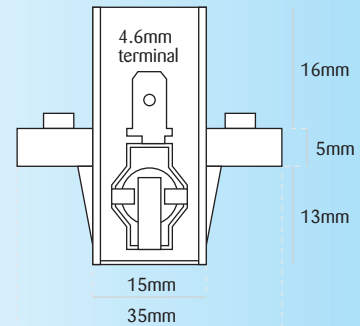
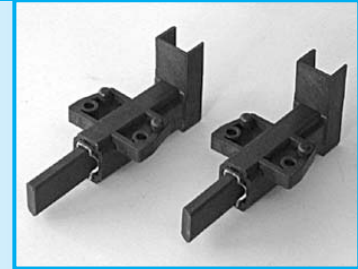
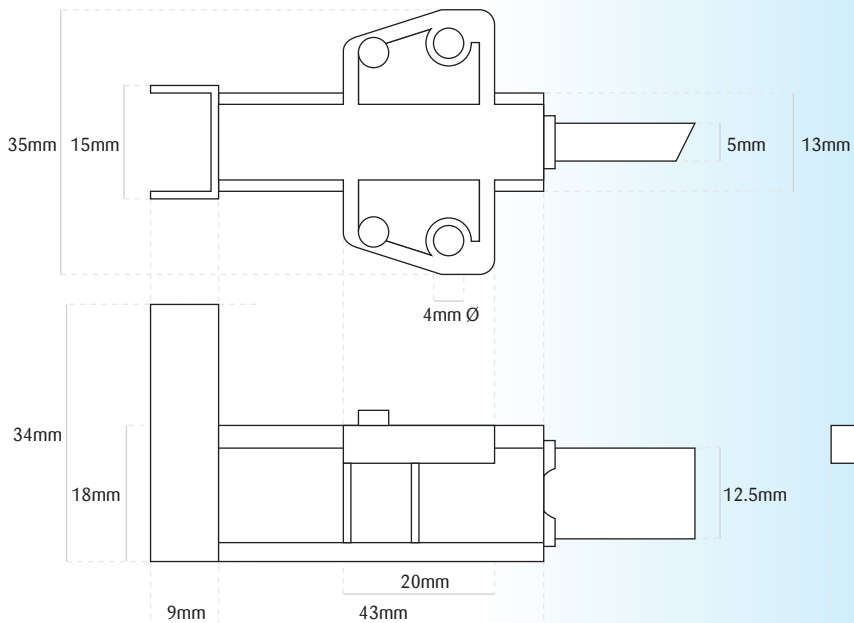



INDESIT

CAR72

1

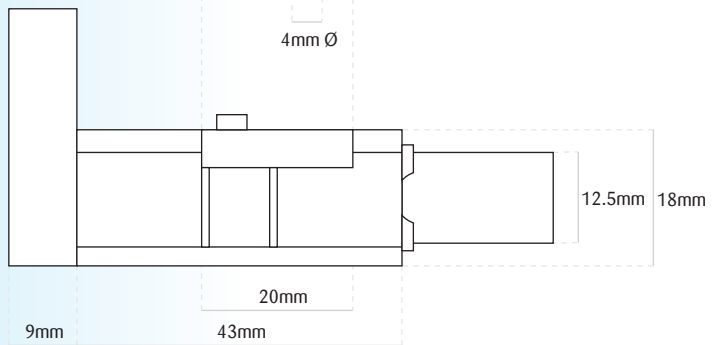
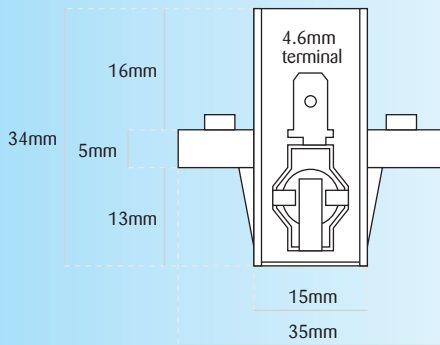
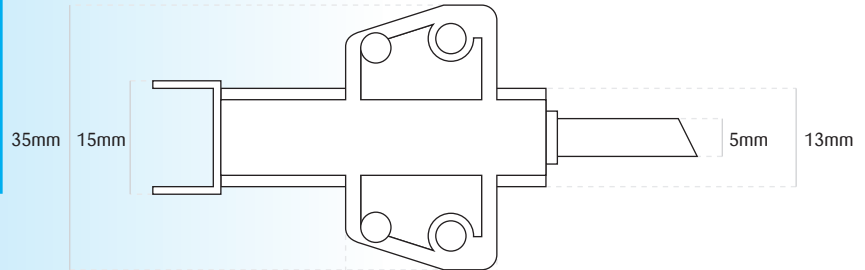
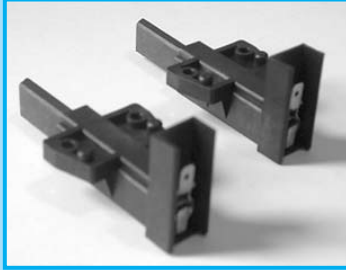

ARISTON / INDESIT / NEW WORLD

CAR73

2

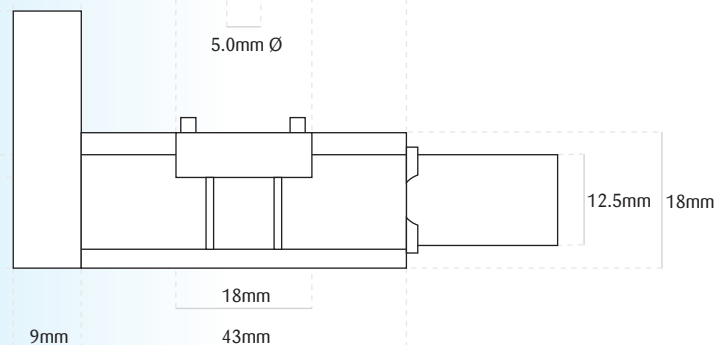
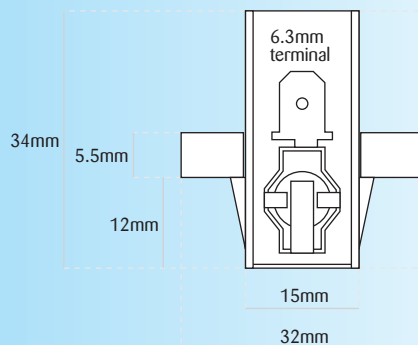
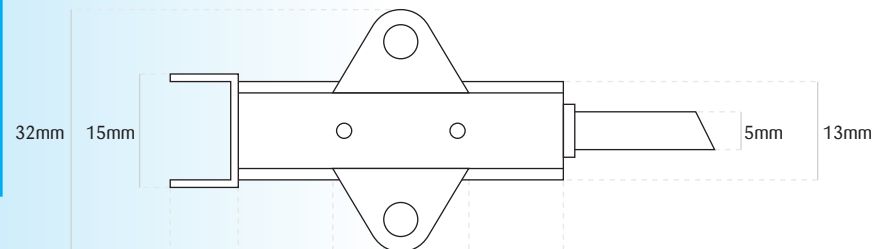
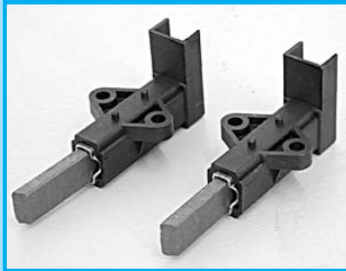

HOOVER

1

CAR75

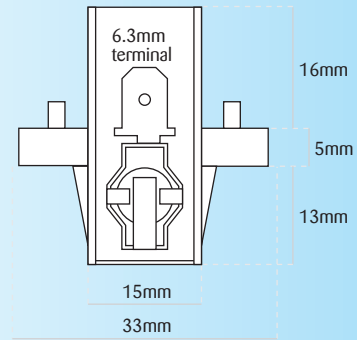
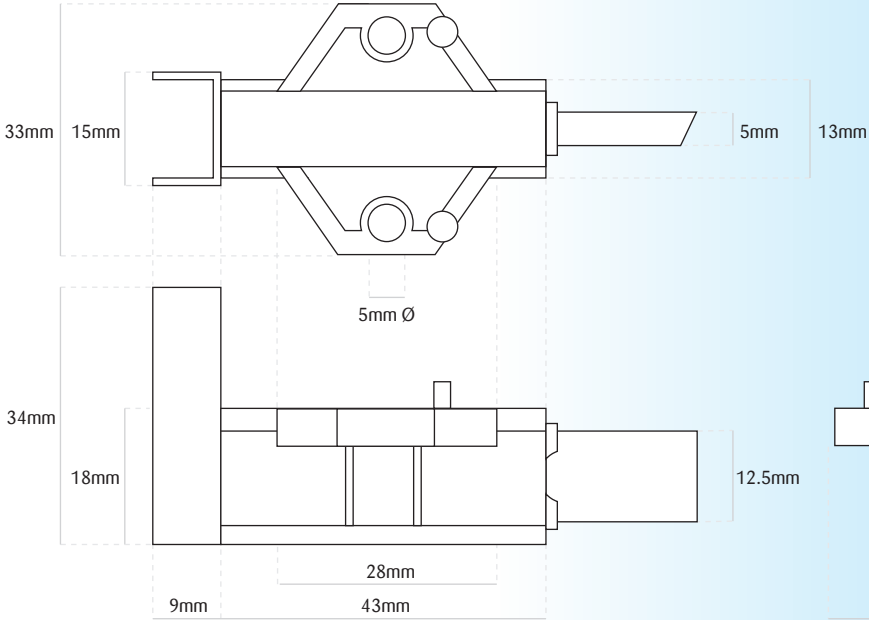
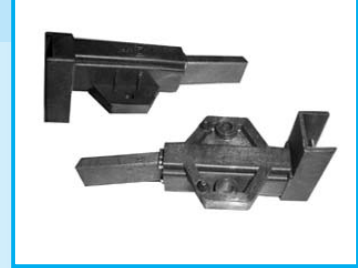

BOSCH / GORENJE (IBMEI motors)

2

CAR76

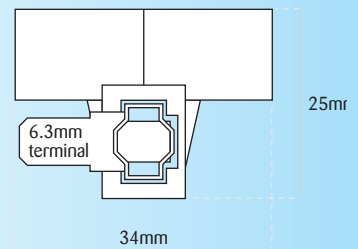
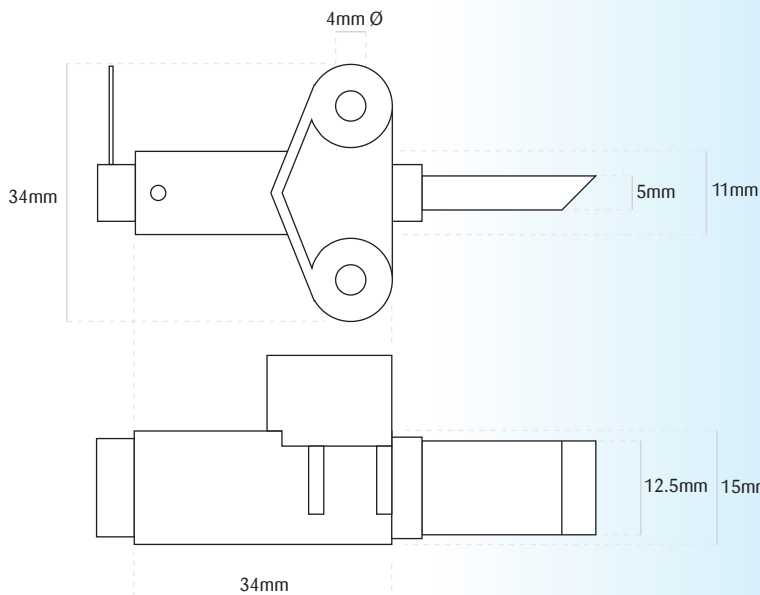



ARISTON (IBMEI motors)

CAR77

1

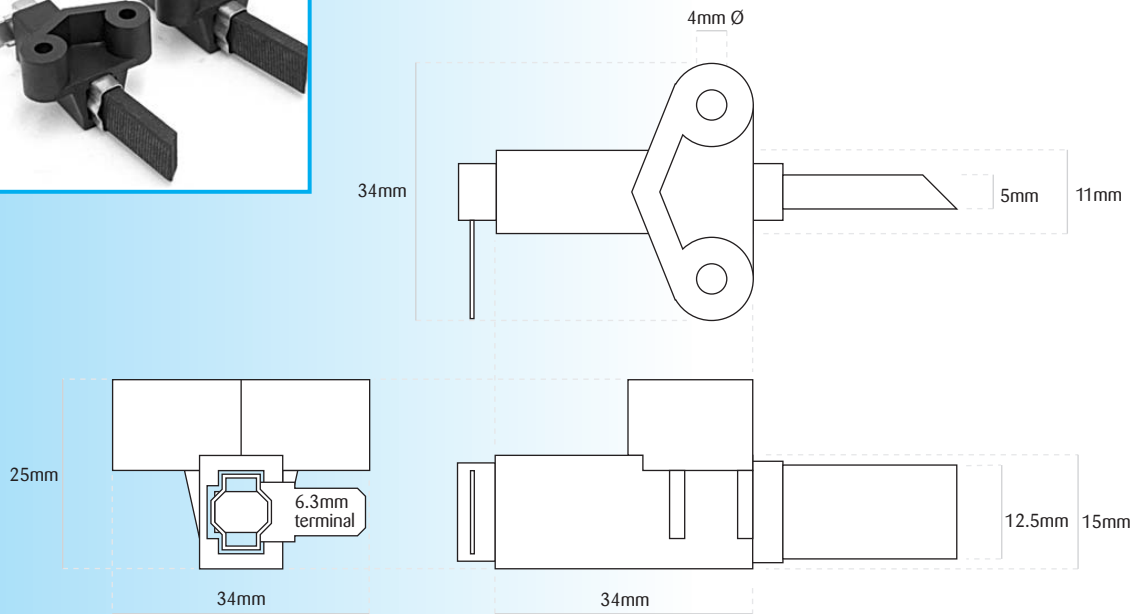
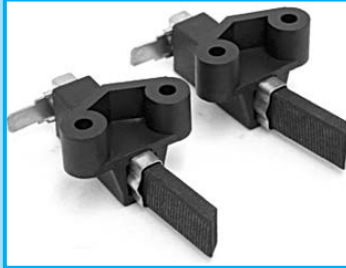

SANGIORGIO / OCEAN (IBMEI motors)

CAR78

2

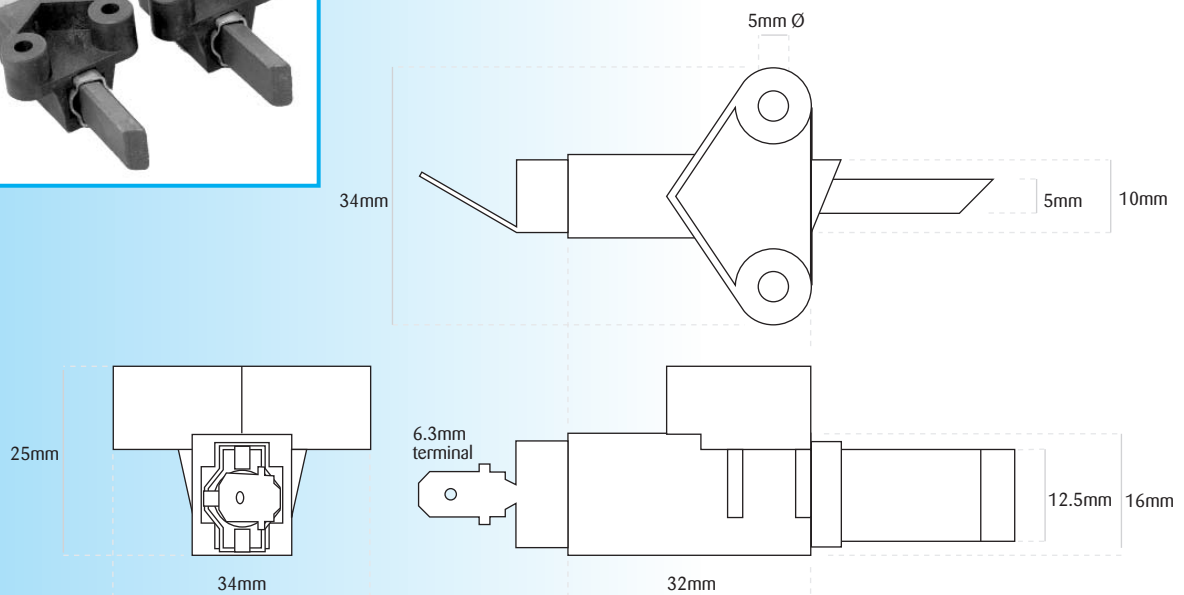
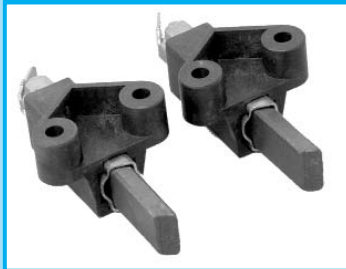

1 BRANDT / INDESIT (SELNI motors)

CAR79

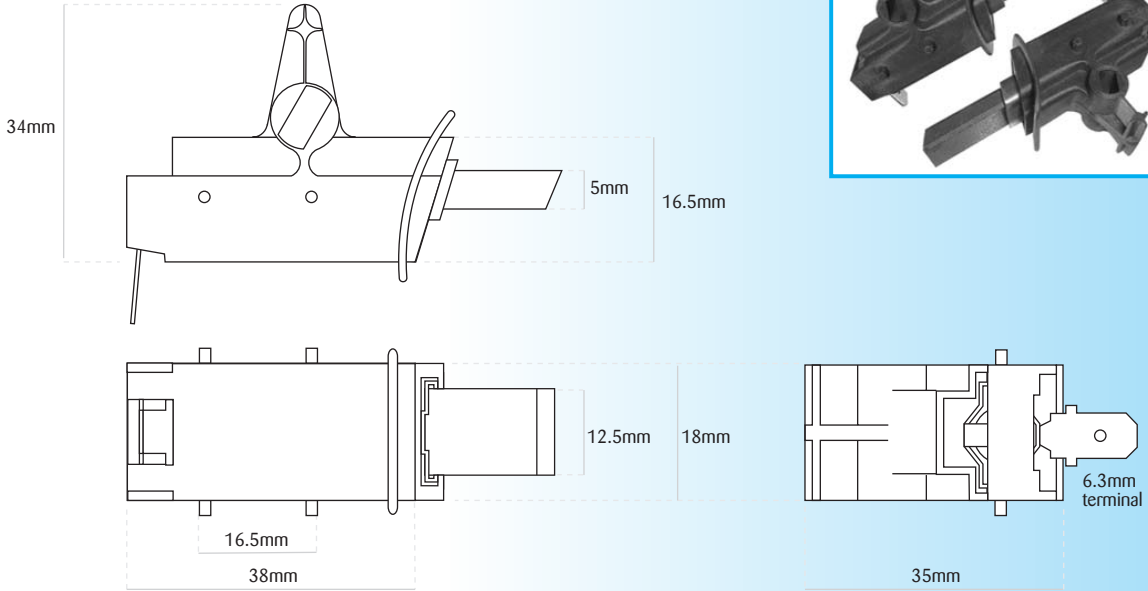

2 PHILCO (INDESCO motors)

CAR88

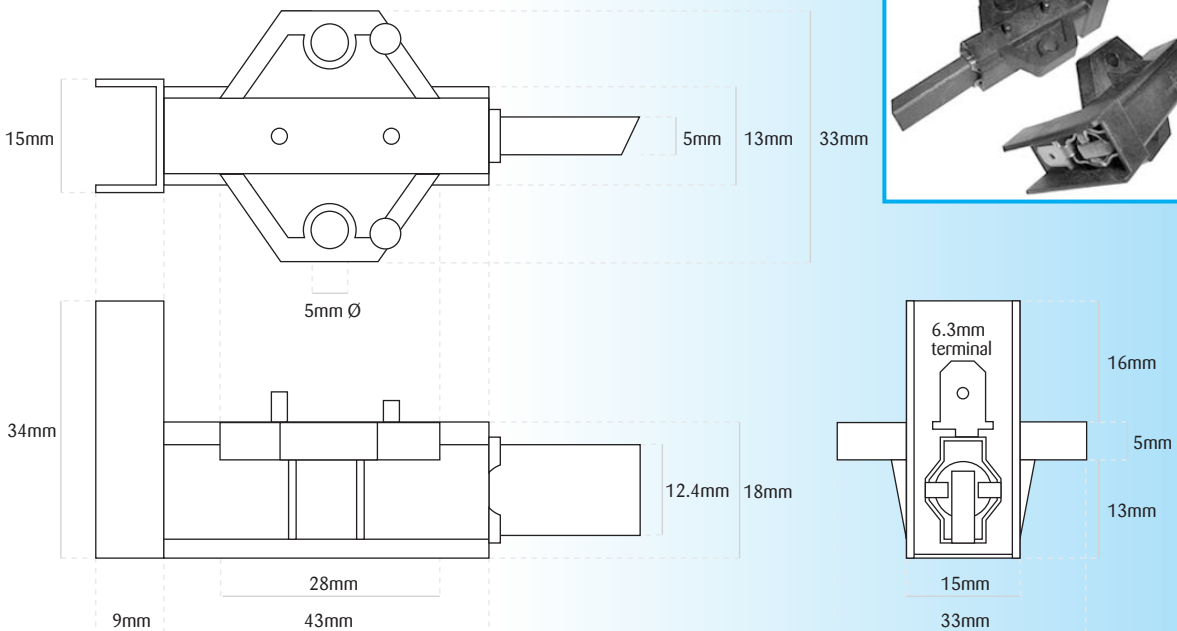
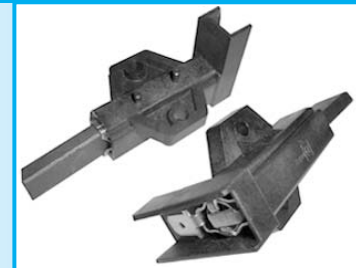



ZANUSSI (SOLE motors)

CAR89

1

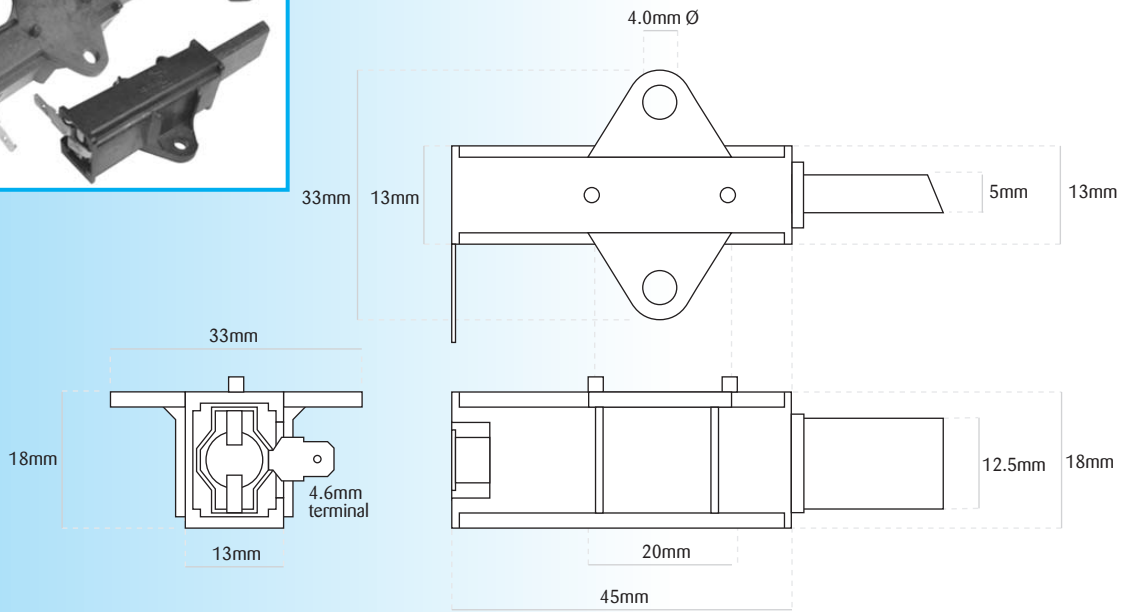

AEG (L type)

CAR90

2

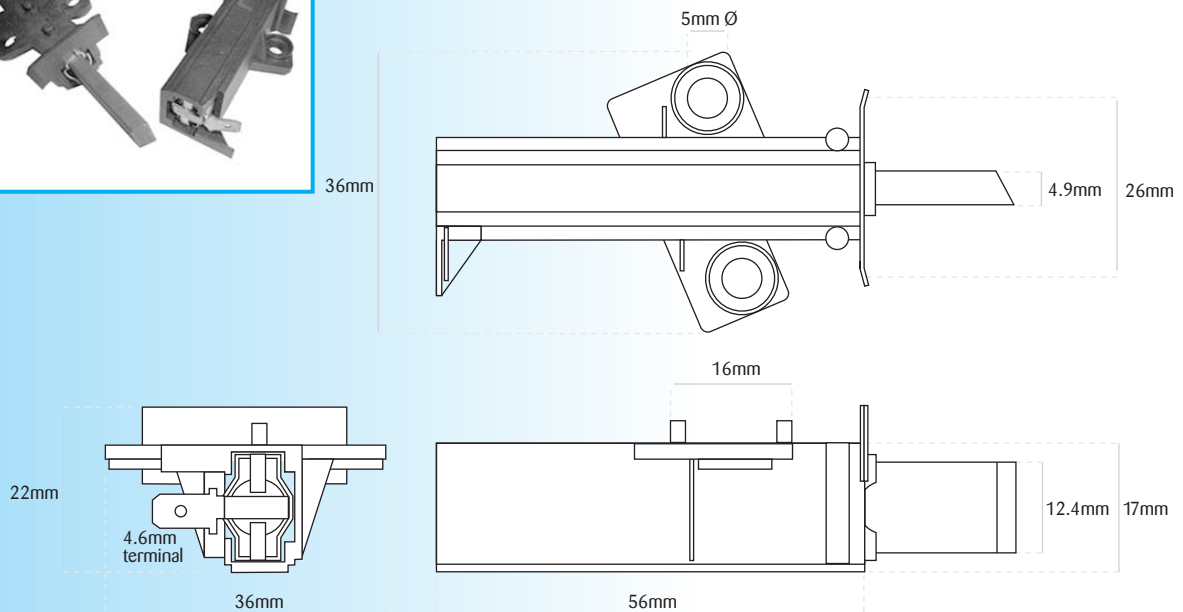

1 CREDA / ELECTRA / HOTPOINT (FHP motors)

CAR91

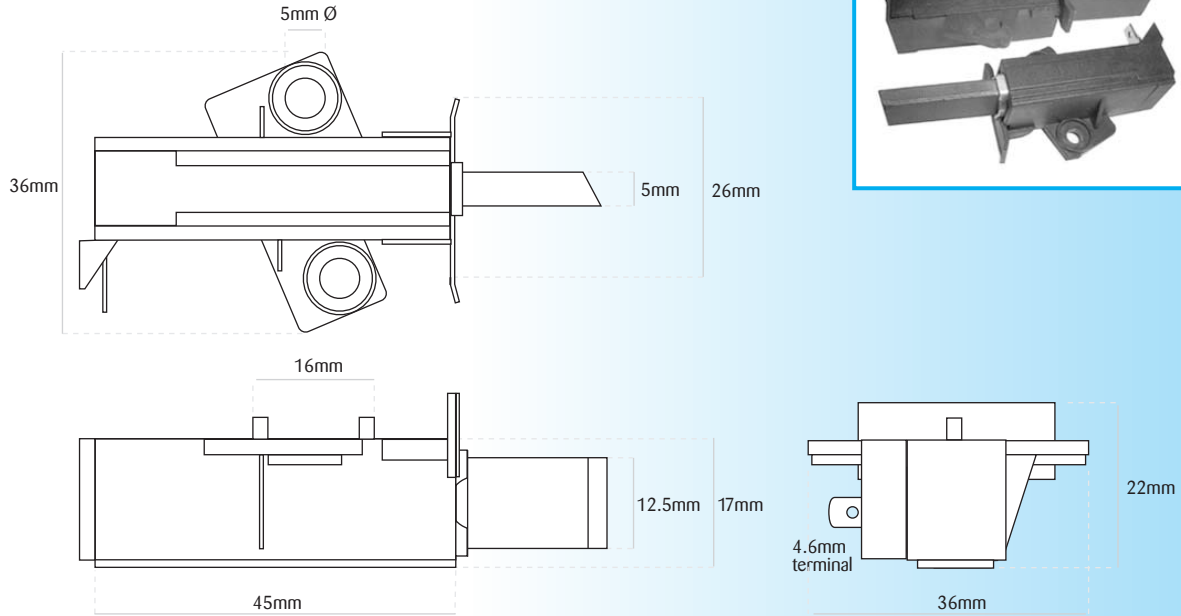

2 SIX MOTORS / QUALTEX (Vacuum motors eg MTR145)

CAR95

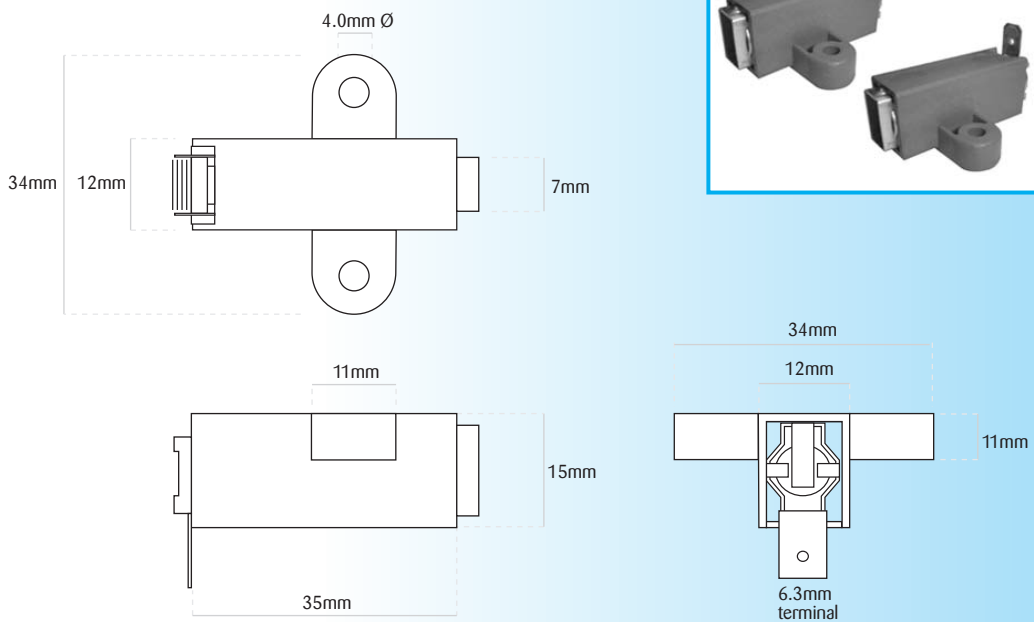



HOTPOINT

1

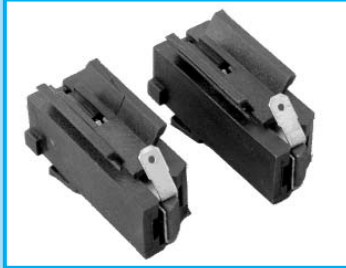

CAR96 (carbon release system) • **HPT36** (standard)

HPT36HT (high temperature) • **HPT161460** (original)

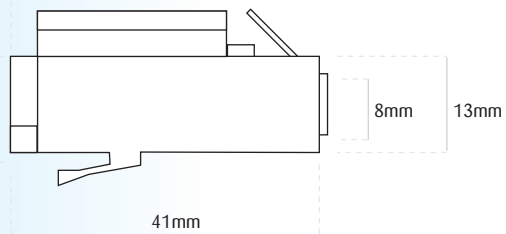
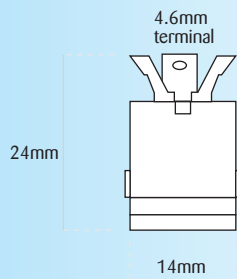
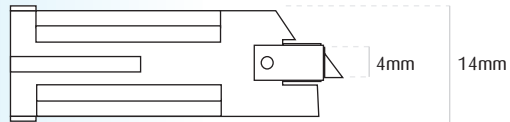

QUALTEX (FISE Vacuum motors eg MTR121)

2

CAR97

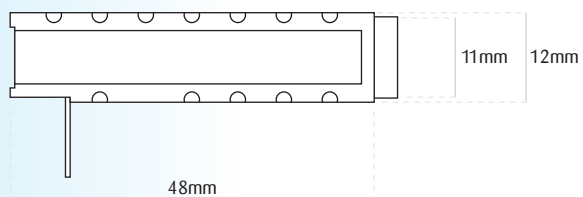
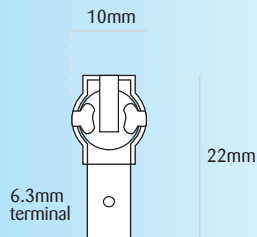
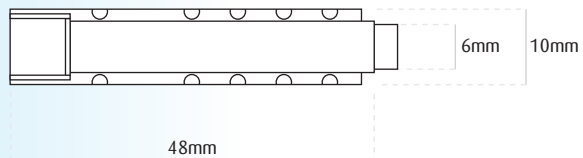

(DELCO-DA1/SD3) CREDA

1

CAR01

dimensions
Contact



dimensions
Carbon

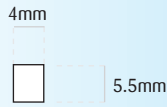

(EA3) KENWOOD

2

CAR38

dimensions
Contact



dimensions
Carbon

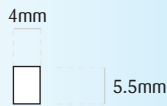

HOTPOINT

3

CAR59

dimensions
Contact



dimensions
Carbon

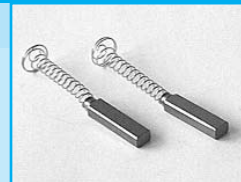
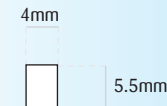
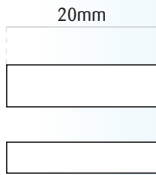

HOTPOINT

4

CAR06

dimensions
Contact



dimensions
Carbon

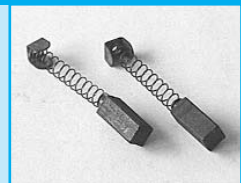
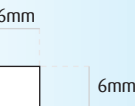

HOTPOINT (VC146)

5

CAR21

dimensions
Contact



dimensions
Carbon

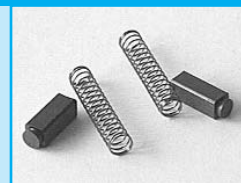
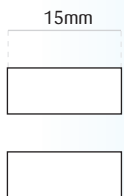

BLACK & DECKER

CAR39

1

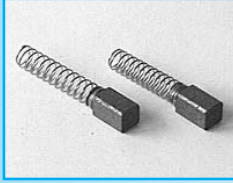

dimensions
Contact

6.5mm Ø



dimensions
Carbon

10mm



6.2mm



6.2mm

BLACK & DECKER (PT5051)

CAR09

2

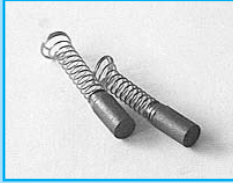

dimensions
Contact

8mm Ø



dimensions
Carbon

10mm



6.3mm Ø



HOOVER (VC107)

CAR15

3

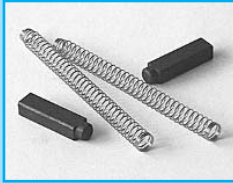

dimensions
Contact

6mm Ø



dimensions
Carbon

24mm

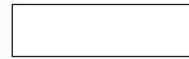

6mm



7mm

HOTPOINT

CAR58

4

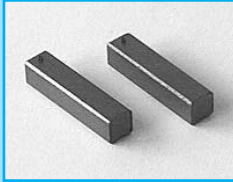

dimensions
Contact

NONE

dimensions
Carbon

33mm



7mm



7mm

(DA9/SD11) SERVIS

CAR02

5

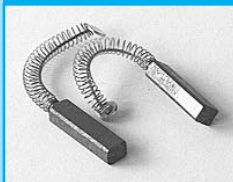

dimensions
Contact

6mm Ø



dimensions
Carbon

24.5mm



5.5mm



7.1mm



1 (EA1) KENWOOD

1

CAR13

dimensions
Contact

10.5mm Ø



dimensions
Carbon

17mm



5.5mm



7.1mm

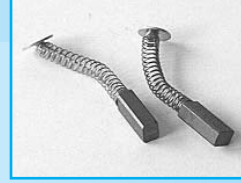

2 HOOVER (VC143)

2

CAR20

dimensions
Contact

6mm Ø



dimensions
Carbon

14.5mm



6.3mm



7.9mm

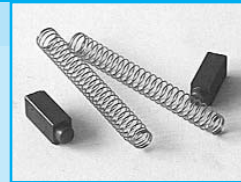

3 HOOVER (VC67)

3

CAR12

dimensions
Contact

7mm Ø



dimensions
Carbon

12mm



6.3mm



8mm

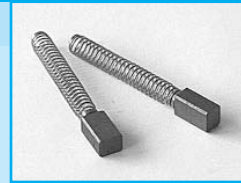

4 NUMATIC

4

CAR68

dimensions
Contact

9mm



7mm

dimensions
Carbon

28.5mm

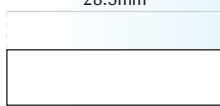

6mm



8mm



5 ASKO / BLOMBERG / BOSCH / SIEMENS

5

CAR83

dimensions
Contact

6mm



5mm

dimensions
Carbon

24.5mm



6.3mm



8mm





(DA25) HOOVER

CAR04

1

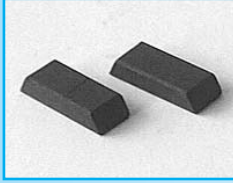

dimensions
Contact

NONE

dimensions
Carbon

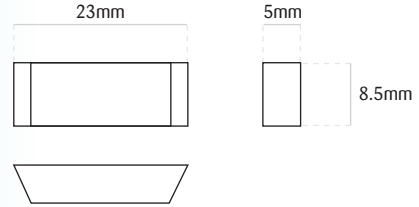

(VC52) ELECTROLUX

CAR10

2

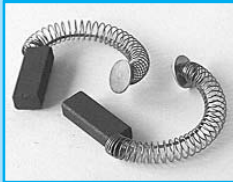

dimensions
Contact

10.5mm Ø



dimensions
Carbon

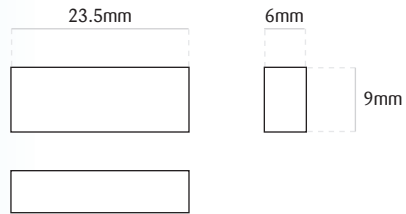

HOTPOINT (SD19)

CAR27

3

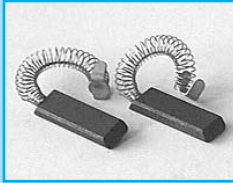

dimensions
Contact

9mm



5mm

dimensions
Carbon

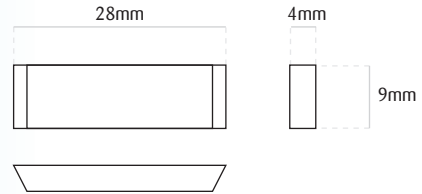

COLUMBUS DIXON

CAR40

4

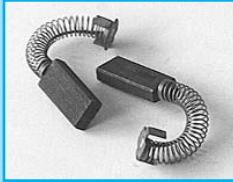

dimensions
Contact

7mm Ø



dimensions
Carbon

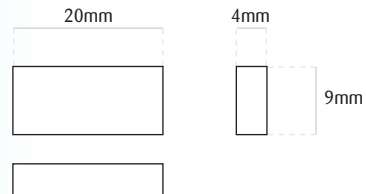

HOOVER (VC157)

CAR43

5

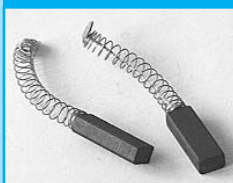

dimensions
Contact

6.5mm Ø



dimensions
Carbon

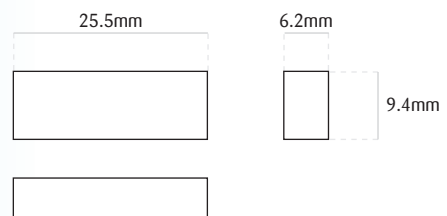



1 KIRBY

CAR56

dimensions
Contact

7.5mm Ø



dimensions
Carbon

18.5mm



6.1mm



9.4mm

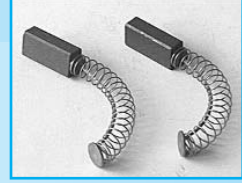

2 (VC141) HOOVER

CAR18

dimensions
Contact

7.5mm Ø



dimensions
Carbon

23mm



6.3mm



9.4mm

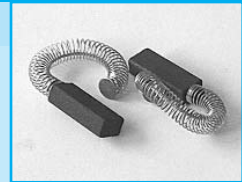

3 (VC100) HOOVER

CAR14

dimensions
Contact

6.5mm Ø



dimensions
Carbon

18mm



6.3mm



9.5mm



4 (VC142/SD2) HOOVER

CAR19

dimensions
Contact

7mm Ø



dimensions
Carbon

23mm



6.3mm



9.5mm

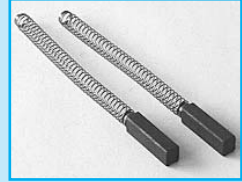

5 (VC148) HOOVER

CAR23

dimensions
Contact

12mm



5mm

dimensions
Carbon

28.5mm



6.3mm



9.5mm

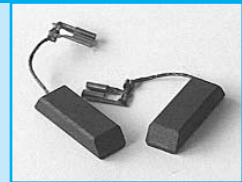

(LC10) INDESIT

CAR29

1

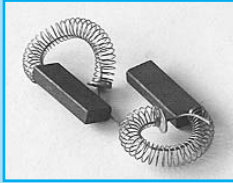

dimensions
Contact



dimensions
Carbon

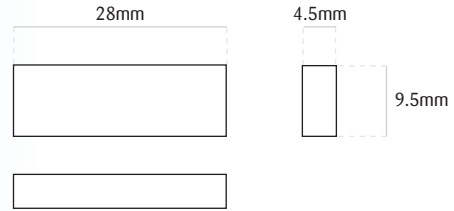

(SD24) PHILIPS

CAR24

2

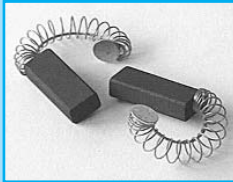

dimensions
Contact



dimensions
Carbon

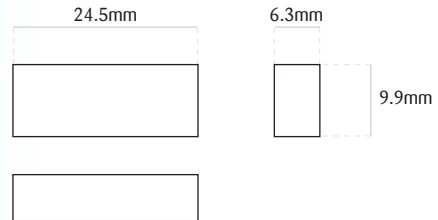

MIELE

CAR80

3



dimensions
Contact

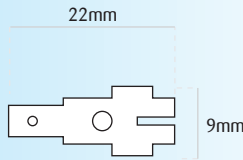

dimensions
Carbon

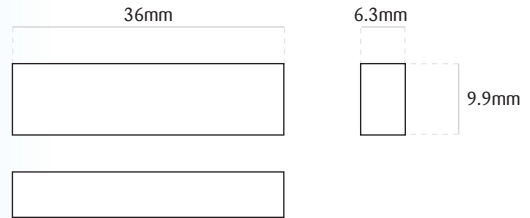

HOTPOINT (SD21 "EMD" MOTOR)

CAR34

4

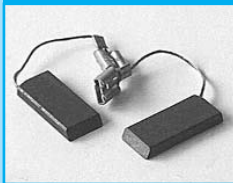

dimensions
Contact

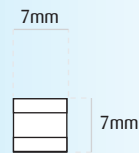

dimensions
Carbon

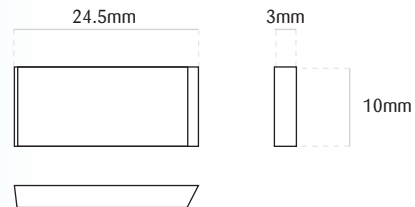

PHILCO

CAR62

5

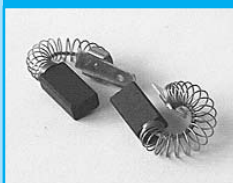

dimensions
Contact

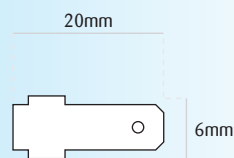

dimensions
Carbon

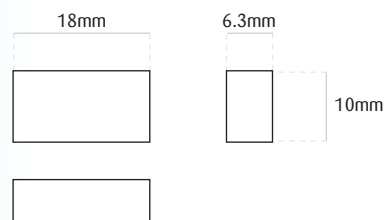



HOTPOINT

1

CAR63

dimensions
Contact

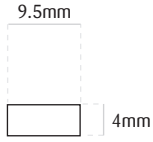

dimensions
Carbon

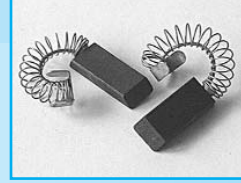
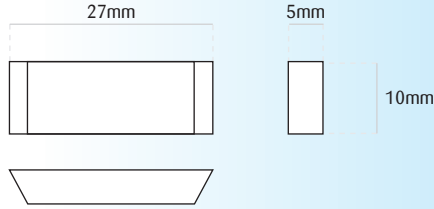

MIELE

2

CAR81

dimensions
Contact

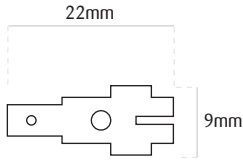

dimensions
Carbon

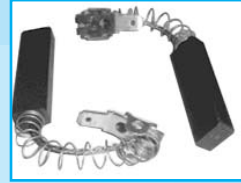
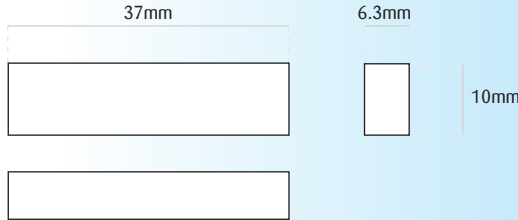

DYSON (YDK-MOTORS)

3

CAR94

dimensions
Contact



dimensions
Carbon

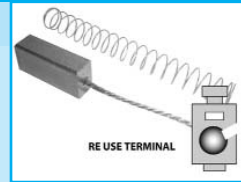
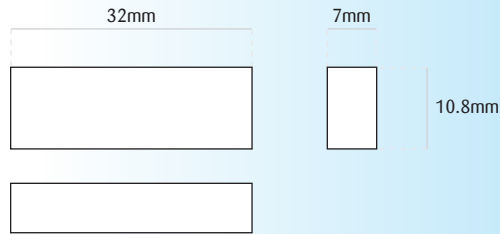

NUMATIC

4

CAR85

dimensions
Contact

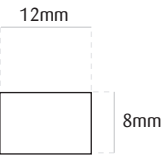

dimensions
Carbon

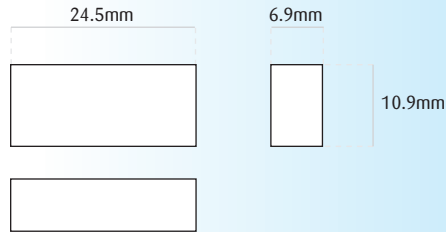

NUMATIC

5

CAR86

dimensions
Contact

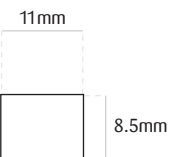

dimensions
Carbon

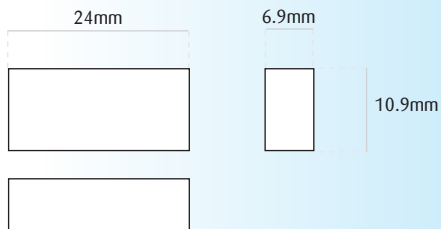

(VC158-ISKRA/DOMEL MOTORS) ELECTROLUX

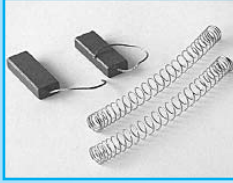

CAR47

1

dimensions
Contact

7.5mm Ø



dimensions
Carbon

29.5mm

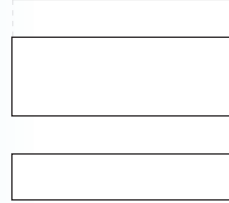

6.3mm

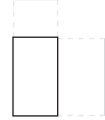

11mm

(VC154) AQUAVAC

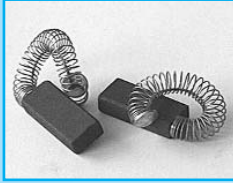

CAR45

2

dimensions
Contact

7.5mm Ø



dimensions
Carbon

24.5mm



6.3mm

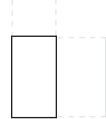

11.1mm

ELECTROLUX/HOOVER/LINDHAUS/NILFISK/TASKI/VAX



CAR71

3

dimensions
Contact

7mm Ø



dimensions
Carbon

24.5mm

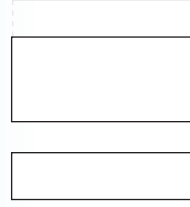

6.3mm

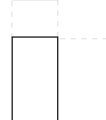

11.1mm

HOOVER



CAR92

4

dimensions
Contact

7mm Ø



dimensions
Carbon

31mm

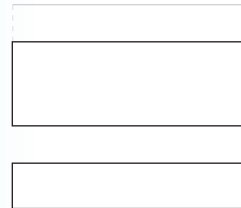

6.1mm

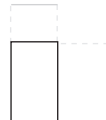

11.2mm

(KM51/SD14) HOOVER



CAR05

5

dimensions
Contact

NONE

dimensions
Carbon

24mm

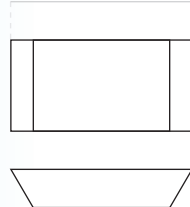

5mm

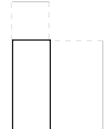

12mm





SERVIS (SD26)

1

CAR36

dimensions
Contact

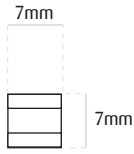

dimensions
Carbon

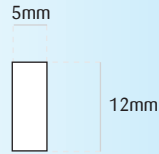
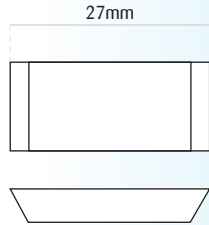

ARISTON (IB MEI MOTORS)

2

CAR60

dimensions
Contact

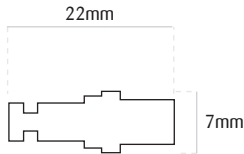

dimensions
Carbon

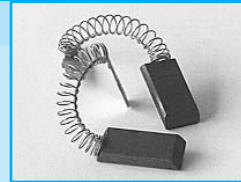
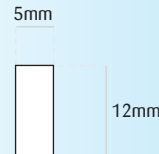
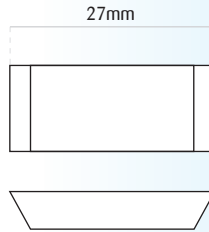

BOSCH/SIEMENS

3

CAR70

dimensions
Contact

NONE

dimensions
Carbon

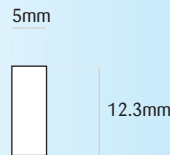
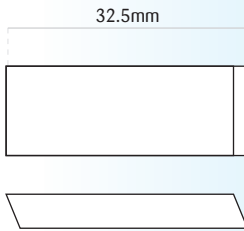

BOSCH

4

CAR93

dimensions
Contact

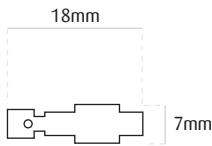

dimensions
Carbon

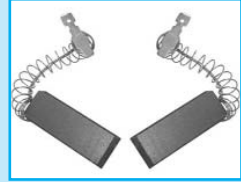
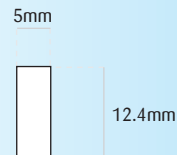

(SD29-AEG MOTORS) AEG / CREDA / HOOVER

5

CAR48

dimensions
Contact

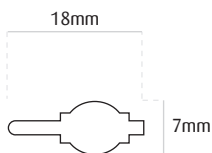

dimensions
Carbon

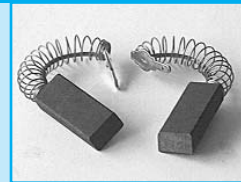
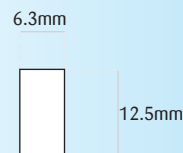
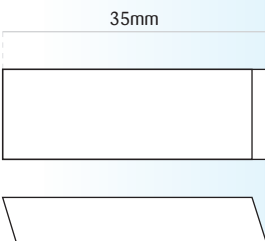

HOOVER (KM81/SD22)

1

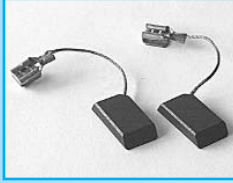

dimensions
Contact

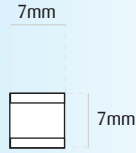

dimensions
Carbon

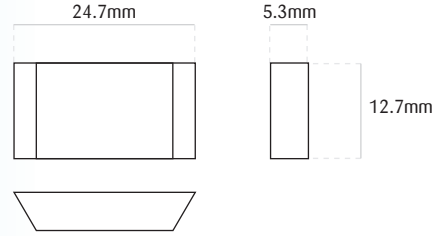

HOOVER

CAR54 • CAR54M (Morganite)

2

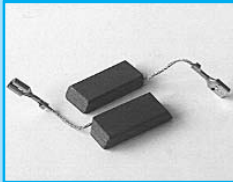

dimensions
Contact

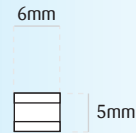

dimensions
Carbon

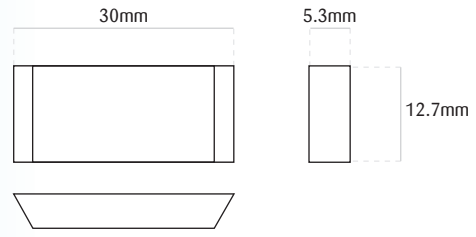

BOSCH

CAR84

3



dimensions
Contact

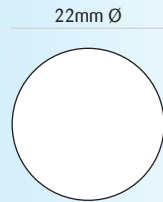

dimensions
Carbon

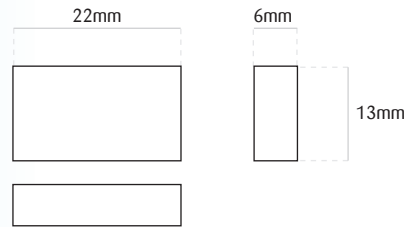

MIELE

CAR74

4

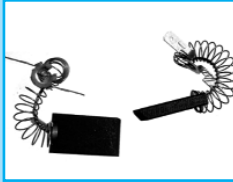

dimensions
Contact

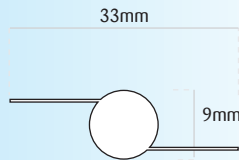

dimensions
Carbon

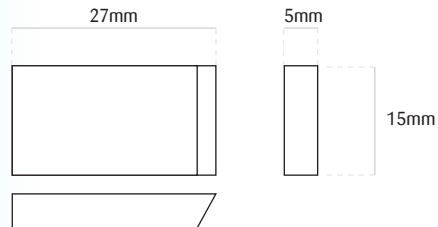

(INDUSTRIAL MOTORS)

CAR87

5



dimensions
Contact

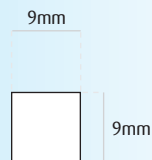

dimensions
Carbon

